

FAPA

System for expanded control/testing IR FPA sensors

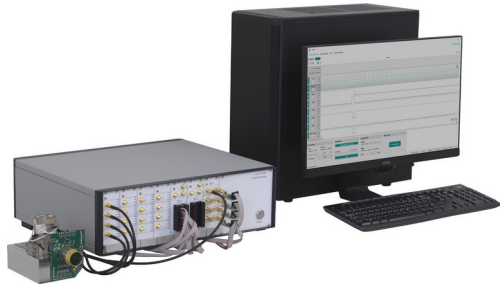

Fig. 1. CONIR universal system for control of IR FPA sensors



Fig. 2. FAPA-N system for response/noise tests of IR FPAs/camera cores

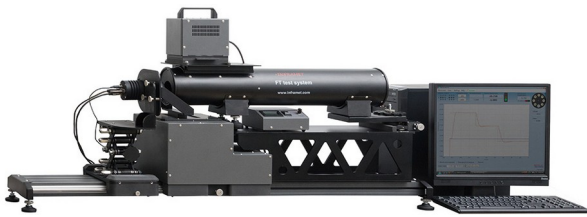

Fig. 3. FAPA-I system for image quality tests of IR FPAs/camera cores

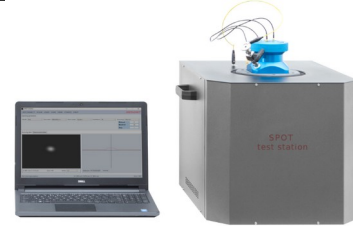

Fig. 4. FAPA-C system for spatial responsivity tests of raw IR FPAs



Fig. 5. FAPA-S system for spectral tests of IR FPAs/camera cores

1 Introduction

The term IR FPA sensors (focal plane array) means array of detectors sensitive to IR light that can potentially generate electronic two dimensional image when located at focal plane of an IR objective. However, in detail the term IR FPA sensors typically describe image sensors sensitive to thermal radiation in spectral range from about $3\mu\text{m}$ to about $15\mu\text{m}$. Further on, on criterion of spectral band the IR FPA sensors are divided into two groups: 1)MWIR FPAs (middle wavelength infrared FPAs) of spectral band typically not wider than $3\mu\text{m}$ to $5\mu\text{m}$; 2)LWIR FPAs (long wavelength infrared FPAs) of spectral band not wider than $7.5\mu\text{m}$ to $14\mu\text{m}$. In addition, on criterion of work temperature IR FPA sensors are divided into two groups: 1)cooled FPAs (both MWIR and LWIR sensors) and non cooled IR FPAs (almost always LWIR FPAs). Finally, it should be noted, that the term IR FPA typically does not cover FPAs sensors of spectral band located below $3\mu\text{m}$ that are considered as a separate group (SWIR FPA sensors). From desing point of view IR FPA sensors offered commercially on the market are built by combining array of IR detectors (raw IR FPA sensor) with read out electronic system.

IR FPA image sensors are the most important block of thermal imagers. The latter systems can be built using two main ways: 1)to purchase IR FPA sensor integrated with a miniaturized control/image processing electronics (thermal camera core) capable to generate standard electronic video image and later to combine it with optical objective, optional cooler, and mechanical case; 2) to purchase IR FPA sensor, to develop suitable miniaturized control/image processing electronics, and later to combine created thermal camera core with optical objective, optional cooler, and mechanical case. In both cases IR FPA sensor is the crucial starting point for design process of thermal imagers.

Technology of IR FPA sensors is very difficult and has been mastered only by not more than a dozen of manufacturers worldwide. However, there are dozens of scientific institutes/companies that carry out work on development of new IR FPA sensors. Both manufacturers and research institutes need scientific apparatus to control/characterize IR FPA sensors that they manufacture or develop.

Testing IR FPA sensors is not standardized. However, IR FPA sensors are typically characterized using a set of parameters used to characterize thermal imagers. There are three main groups of parameters: 1)noise/sensitivity parameters, 2)image quality parameters, 3)spectral parameters. In spite of similarity of characterization parameters, the systems for testing IR FPA sensors differ a lot from systems for testing thermal imagers due to two reasons. First, universal control electronics capable to control IR FPAs of different ROIC architecture is needed to generate images in one of standards of

FAPA

System for expanded control/testing IR FPA sensors

electronic video image. Second, some optical blocks are needed to simulate optical objectives used in thermal imagers. There are also some other minor differences.

2 What is FAPA?

FAPA is a quasi universal system for expanded control/testing IR FPA sensors at different stages of life time of such image sensors: 1)raw IR FPA sensors (before integration with readout electronics) - limited testing, 2) typical IR FPA sensors (array of detectors integrated with readout electronics), 3)thermal camera cores (IR FPA sensor integrated with specialized control electronics).It can be also used for optional testing of complete thermal imagers.

FAPA is optimized for use by scientific institutes that carry our research on development of IR FPA image sensors. However, it is also a near perfect tools for manufacturers of IR FPAs and test laboratories that need expanded control/testing IR FPA sensors.

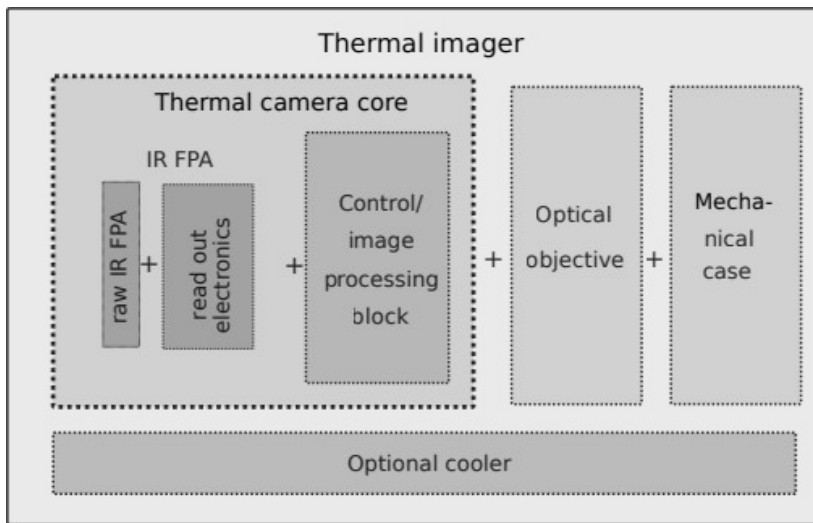

Fig. 6. Stages of design of thermal imagers

From design point of view FAPA is a turnkey system that generates IR radiation of precisely controlled spatial and temporal distribution to the input plane of tested IR FPA, carries out electronic control the tested IR FPA; and finally carries out semi-automatic analysis of the output signal necessary to perform characterization of the tested IR FPA sensors (or a thermal camera core). The system enables measurement of all important parameters (noise/sensitivity, image quality, and spectral parameters) of raw IR FPA sensors, IR FPA sensors and camera cores. Sensors of different spectral bands (LWIR or MWIR), cooled or non cooled can be tested.

3 General concept of FAPA system

FAPA is a modular system built from a series of modules that can be configured to create a series of different sub-systems intended for measurement of different groups of parameters. However, basically all modules of FAPA can be divided into three groups (blocks):

1. Radiometric tools,
2. Sensor control/image processing tools,
3. Image acquisition/computing tools.

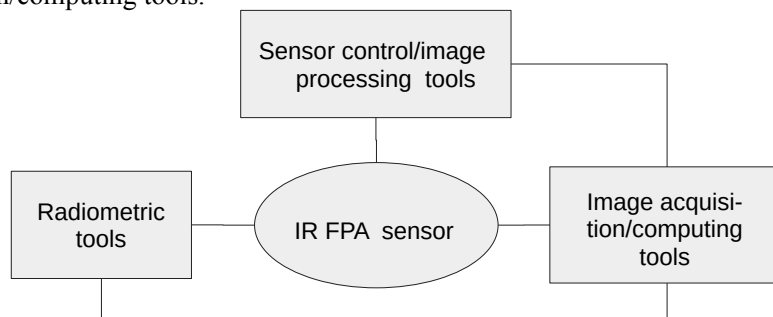

Fig. 7. Groups of tools used by FAPA system

FAPA

System for expanded control/testing IR FPA sensors

The first group includes modules that generate necessary radiometric stimulus to input of tested IR FPA sensor. This stimulus can be in different forms: large uniform image, or edge/line/pinhole image. This group includes such modules like blackbodies, IR sources, collimators, optics, mechanical stages, optical integrators, optical projectors, monochromators.

The second group includes a series of electronic tools that form a quasi universal electronic controller system for control of complete IR FPA sensors. This system (coded as CONIR) enables three main functions:

- 1) to provide input electronics signals to the tested IR FPA sensor needed to make sensor to generate output signals
- 2) carry out basic signal processing,
- 3) conversion of sensor output signals into a electronic video image in one of standards of electronic video image.

The third group (coded as COMP) is practically a PC set with two types of accessories: 1) frame grabbers to enable acquisition by PC of electronic video image from the CONIR sensor controller, 2) set of specialized computer programs for image processing and calculation of parameters of tested IR FPA sensor on basic of captured images. Different versions of COMP block are needed to support measurement of different groups of parameters of IR FPA sensor/cores.

It should be noted that the second block (coded as CONIR sensor controller) is strictly needed when testing IR FPA sensors. It is not needed when testing thermal camera cores having their own miniaturized sensor controllers. However, in spite of being optional CONIR sensor controller is the most important block of FAPA system.

4 Detail concept of FAPA system

FAPA is a modular system built in form of five semi independent subsystems:

1. CONIR universal controller of IRFPA sensors,
2. FAPA-N system for measurement of noise/responsivity parameters of IR FPA sensors or thermal camera cores,
3. FAPA-I system for measurement of image quality parameters of IR FPA sensors or thermal camera cores,
4. FAPA-C system for measurement of spatial responsivity of raw IR FPA sensors (before integration with ROIC),
5. FAPA-S system for measurement of spectral parameters of IR FPA sensors or thermal camera cores.

All five combined subsystems offer expanded testing of raw IR FPAs, complete IR FPAs, and thermal cameras cores.

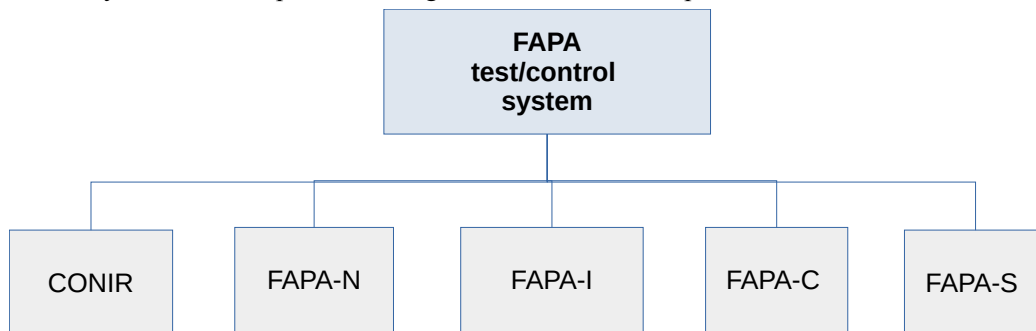

Fig. 8. Main subsystems of FAPA control/test system

These five FAPA subsystems shall be discussed in detail in next sections.

It should be noted that CONIR is main system of FAPA that is strictly needed when testing IR FPA sensors. If camera cores are to be tested then CONIR is not needed.

5 CONIR system

CONIR is an universal system for control of IRFPA sensors capable to control great majority of IR FPA sensors offered on the market. The system enables image processing up to 4096 pixels per line and up to 4096 lines, depending on the available memory.

It can be said that CONIR system is a complete set of tools to run virtually any IR FPA sensor offered on market. For example, CONIR system supports control of FPAs and ROICs from such manufacturers as Lynred, Hamamatsu, IRay, Andanta, Mikro-Tasarim and many others.

CONIR system is optimized for use in R/D projects to develop new/improved IR FPA sensors, thermal camera cores or thermal imagers. It can be used as an independent system for control of IR FPA sensors or as a block of bigger FAPA system for testing IR FPA sensors.

It should be also noted that in optional version it can be used for semi automatic optimization of bias voltages supplied to tested IR FPA sensor.

FAPA

System for expanded control/testing IR FPA sensors

CONIR can be used for control of IR FPAs that generates images using analog outputs. Great majority (probably over 99%) of thermal imagers are built using such image sensors. Further on, image resolution of tested IR FPAs can be as high as 4096×4096 piksels (see Table 1).

5.1 Control capabilities

Finally, CONIR literally can be used for control of IR FPA sensors having number of outputs not higher than 4 (four is max number of CONIR analog inputs). However, practically analog IR FPAs having 8/16 outputs can be tested too. Number of active outputs is to be limited to 4 and test image is acquired. It takes more time (lower capture speed FPS) but the captured test image is basically identical as for case when 8/16 outputs are used.

Table 1. Approximate maximal resolution of IR FPA sensor that can be achieved using CONIR for a series of different IR FPA sensors having different number of analog outputs.

	Resolution	Bits per pixel	Bytes per frame	Nr. of analog outputs	Pixel clock	FPS
1	8192×8192	14bit ¹	32MB	4	10MHz	0.5
2	4096×4096	14bit ¹	32MB	4	10MHz	2
3	4096×4096	14bit ¹	32MB	1	10MHz	0.5
4	2048×2048	14bit ¹	8MB	4	10MHz	8
5	1024×1024	14bit ¹	2MB	4	10MHz	32
6	640×480	14bit ¹	600kB	1	20MHz	60
7	640×480	14bit ¹	600kB	2	20MHz	120
8	320×256	14bit ¹	160kB	1	10MHz	110
9	320×256	14bit ¹	160kB	2	10MHz	200
10	320×256	14bit ¹	160kB	4	10MHz	350
11	1024×768	14bit ¹	1MB	4	10MHz	40
12	1024×768	14bit ¹	1MB	2	10MHz	20
13	1024×768	14bit ¹	1MB	1	10MHz	10

¹The real size in memory is 16bit

To summarize, frame rates obtained using 4 analog outputs and available sampling rates are sufficient for typical applications. For example ROIC ISC0403 with a resolution of 640×512 in a 2-output configuration, Pixel Rate 12MHz reaches 60 Hz or 4-output, Pixel Rate 12MHz reaches 120 Hz. If the sensor has more than 4 analog outputs (e.g. 8), it can operate on a smaller number of outputs, e.g. 4, 2 or 1.

5.2 CONIR system structure

CONIR system is built as a set of two main subsystems: 1- CONIR controller (Fig. 1), 2-specialized PC set . The first block is made from five main modules: pattern generator, bias generator, analog digital converter, optional preamplifiers, optional SPI/I2C Interface. The hardware components of CONIR controller are delivered in the form of a series of cards enclosed in a single 19" x 3U rack housing.

PC set is actually typical PC having installed frame grabber card and software package.

5.3 Conir controller

Conir controller is a system composed from five main modules: pattern generator, bias generator, analog to digital converter, pre-amplifier module (option), SPI/I2C Interface (option).

Pattern generator

The clock signal generation card provide the clock signals necessary for the proper operation of the detectors to be tested (example: master clock, video synchronization signals)

Specification of clock signal generator:

- 8 output channels per card, 2 cards for typical version, total 16 channels
- up to 32 channels for optional version,
- up to 16 Mbits of memory per channel,
- clock rate up to 250 MHz,
- internal or external clock,
- internal or external trigger,

FAPA

System for expanded control/testing IR FPA sensors

- high level voltage: 1.8V, 2.5V, 3.3V, 5.5V,
- output impedance: 50 Ω ,
- output connectors: SMA type
- user friendly graphical software
- controlled via Ethernet

Bias generator

The bias voltage generation card provide the bias voltages necessary for proper operation of the detectors to be tested.

Specification of bias voltage generator:

- 4 output channels per card, 4 cards for typical version (16 channels)
- up to 24 channels for optional version,
- bias voltage ranges: 0-5V 100mA (0.0763mV step) or 0-15V 50mA (0.2289mV step),
- positive or negative polarization,
- set point accuracy $\leq 0.1\%$
- set point resolution 16 bit,
- output current limit 0-100mA
- average output noise: 3 nV/ $\sqrt{\text{Hz}}$ @ 1 kHz, 260 nV/Hz @ 1Hz
- integrated self-test
- channels isolated from the housing
- easy controlled via PC USB

Analog to digital converter

The A/D converter card allows to convert analog signals from the detector into digital image data.

Specification of analog to digital converter:

- 4 A/D conversion channels per card,
- A/D converters input voltage range: from -5V to 5 V (max. span 5.86V),
- A/D dynamic range: 14-bits
- probe rate up to 40MHz per channel
- integrated analog gain & offset

Pre-amplifier module (option)

The pre-amplifier modules are designed to amplify the weak signals from the tested sensor and adapt them to the input of the A/D converter. This block is optional and needed in rare case of sensors that generate very weak analog signals.

Specification of pre-amplifier modules:

- independent gain control from 1 to 3,
- offset control
- ultra-low noise: 1 nV/ $\sqrt{\text{Hz}}$ @ 1 kHz.

SPI/I2C Interface (option)

This module is used to communicate with the sensor via the SPI or I2C interface and allows you to control the reset pin.

Specification of SPI/I2C modules:

- isolated connection
- voltage supply range: 1,8V – 5V
- two output pins (open-collector) and two input pins
- easy controlled via PC

5.4 Specialized PC set

Specialized PC set is built from three main blocks: PC, frame grabber card, software.

PC set

standard PC tested for frame grabber compatibility, CPU: Intel or AMD, RAM: ≥ 16 GB, SSD: ≥ 240 GB OS: Windows 10 or better

Digital acquisition card (frame grabber)

A digital data acquisition card is used to capture digital image data for further analysis and processing.

Specification of digital acquisition card:

- parallel Camera Link Base input
- up to 200 megabytes per second
- up to 28 bit LVDS per card
- up to 85MHz speed
- TTL configurable I/Os

Software

CONIR Control program offers three main functionalities: Pattern editor, Bias generator, Video capture.

FAPA

System for expanded control/testing IR FPA sensors

Detail technical specifications of CONIR sensor controller is presented in a separate CONIR data sheet.

6 FAPA-N system

The aim of FAPA-N system (see photo at Fig. 2) is to enable noise/responsivity tests of IR FPA sensors and thermal camera cores. In detail, FAPA-N enables measurement of following parameters:

Table 2. Test capabilities of of FAPA-N

1.	Thermometric response parameters: thermometric response function TRF, signal transfer function SiTF, dynamic range (relationship between output image brightness in digital levels dL and input sensor irradiation in thermometric units: mK),
2.	Radiometric response parameters: radiometric response function RRF, responsivity, linearity, dynamic range (relationship between output image brightness in digital levels dL and input sensor irradiation in radiometric units: W/cm ² . Attention: information on spectral sensitivity is needed.
3.	Electric noise parameters: temporal noise, high frequency spatial noise, low frequency spatial noise (rms of different types of noise present in image generated by the sensor in electric unit: mV
4.	Noise related parameters: NETD, FPN, NEP, D* (sensor performance parameters calculated on basis of measured response parameters and electric noise parameters,
5.	Two point NUC parameters: Gain/offset correction factors
6.	Bad pixels (determined using different criteria: responsivity, electric noise parameters, pixel NETD, pixel D*, pixel gain, pixel offset),
7.	3D noise model, NPSD, quantum efficiency (option)

Measurements can be carried out for total area, selected area of tested IR FPA sensor, total area minus bad pixels, selected area minus bad pixels.

FAPA-N system performs three functions:

1. Quasi uniform irradiation of tested IR FPA sensor (responsible TCB4D blackbody, MPAB blackbody, OIM imitators),.
2. Electronic control of tested IR FPA sensor by delivery of proper bias voltages and clocking. This function is carried out by CONIR controller presented in Section 5 .
3. Remote control of radiation modules (blackbodies)
4. Image acquisition/processing/computing of video images generated by CONIR block.

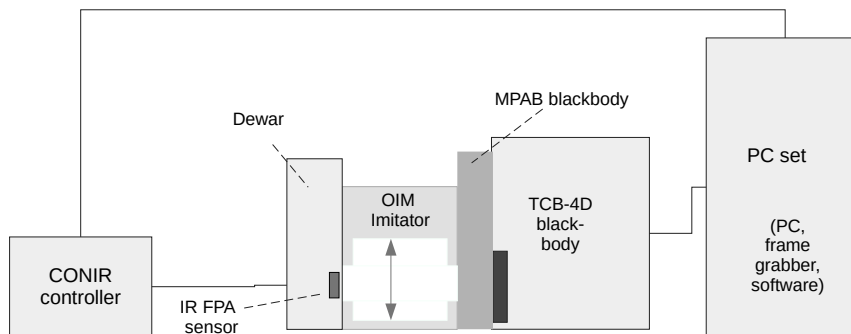

Fig. 9. Block diagram of FAPA-N station

From detail design point of view FAPA-N is built from following modules : TCB-4D blackbody, MPAB movable blackbody, set of exchangeable four OIM optics imitators, PC, set of frame grabber cards, test software (Fig. 9).

Table 3. Specifications of key modules of FAPA-N

Parameter	Value
<i>TCB-4D precision differential blackbody</i>	
Aperture	100 × 100mm
Differential temperature range	-20°C to +80°C at 20°C ambient temperature
Absolute temperature range:	0°C to +100°C
Emissivity	0.98±0.005

FAPA

System for expanded control/testing IR FPA sensors

Temperature uniformity (Temperature spatial uncertainty)	$<0.01^{\circ}\text{C}$ or $0.4\% T-T_{amb} $
Total temperature uncertainty	0.03°C
Set point and resolution	1 mK
<i>MPAB movable blackbody</i>	
Aperture	diameter 100 mm
Emissivity	0.97 ± 0.01
Measurement temperature resolution	1mK
<i>Set of exchangeable four OIM optics imitators</i>	
Number of imitators	4
F-numbers of simulated optics	1,2,3,4
<i>PC</i>	
Type	Standard PC tested for frame grabber compatibility CPU: Intel or AMD, RAM: ≥ 16 GB, SSD: ≥ 240 GB OS: Windows 10 or better
Frame grabbers	1. Analog (PAL/NTSC) 8 – bit: BNC input 2. parallel Camera Link Base input, up to 200 megabytes per second, up to 28 bit LVDS per card, up to 85MHz speed, attention: frame grabbers can be changed if different interfaces are needed
<i>Software</i>	
BRAD Control program	Control of temperature of TCB blackbodies, control of position MPAB blackbody
TAS-FN program	test capabilities as in Table 2

7 FAPA-I system

The aim of FAPA-I system (see photo at Fig. 3 and block diagram at Fig. 10) is to enable image quality tests of IR FPA sensors/ thermal camera cores. In detail, the FAPA-I system FAPA-I enables measurement of following image quality parameters as in table below:

Table 4. Test capabilities of of FAPA-I

<ol style="list-style-type: none">1. MTF modulation transfer function (measured using slanted edge method) – measurement at any position of the sensor,2. Cross-talk (1-calculated on basis of measured MTF, 2)measured directly using spot projection method3. Scanning test (scanning of sensor total area with pinhole/edge image.

FAPA-I enables four functions:

1. Projection of images of exchangeable reference targets on surface of tested IR FPA sensor. The sensor creates image of the reference target. Analysis of quality of this image delivers information on image quality parameters of the sensor.
2. Precision movement of image of the reference target at any desirable location within area of the tested IR FPA sensor.
3. Electronic control of tested IR FPA sensor by delivery of proper bias voltages and clocking (the same fuction of CONIR block as in FAPA-N station).
4. Control of radiation source and mechanical stage responsible for position of projected image,
5. Acquisition of video images generated by tested IR FPA sensor, image processing and calculation of image quality parameters.

FAPA

System for expanded control/testing IR FPA sensors

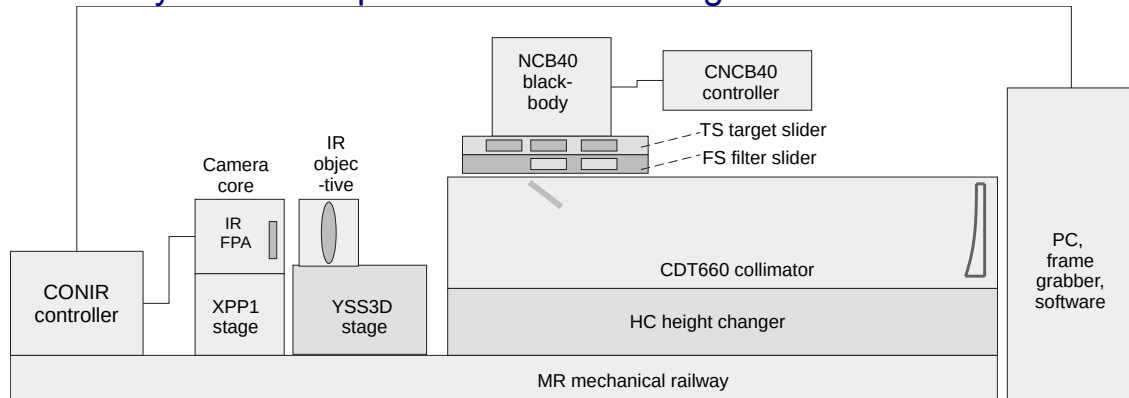

Fig. 10. Block diagram of FAPA-I station

From design point of view FAPA-I is built from following blocks

1. NCB40 blackbody: broadband radiation source,
2. CDT760 HR collimator: reflective optical projector,
3. TS target slider - to enable easy exchange of targets,
4. Set of IR targets - set of targets to be projected
5. FS filter slider - to enable easy exchange of spectral filters
6. Set of spectral filters - set of two spectral shortwave filters used to change spectrum of radiation of image to be projected by collimator
7. Set of reference IR optical objectives - to create image projected by the collimator on the surface of IR FPA sensor
8. YSS3 computerized x-y-z stage - ultra precision x-y-z stage that enables regulation of position of reference IR objective and position of image created by this objective
9. XPP1 platform -manual vertical platform for rough vertical position of tested IR FPA sensor/camera core,
10. CONIR controller – for control of IR FPA sensors (not needed when testing camera cores).
11. XMR mechanical rail – to enable mechanical movement of XPP1 stage, YSS3D stage along optical axis of the collimator,
12. HC height changer – mechanical block that increase height of optical axis of the CDT760 collimator to be equal to optical axis of the IR objective (needed due to mechanical constraints generated by YSS3D stage).
13. PC
14. set of frame grabbers,
15. Control/test software.

Tab. 5. Performance of key modules – FAPA-I

Parameter	Value
<i>NCB40 blackbody</i>	
Type	Non – calibrated
Aperture	40 × 40mm
Differential temperature range	-10°C to +10°C at 20°C ambient temperature
Emissivity	0.96±0.01
<i>CDT760HR off-axis collimator</i>	
Type	Reflective, off-axis
Aperture	70mm
Focal length	600mm
Spectral range	0.4 – 15 μm
Spatial resolution	≥ 60 lp/mrad
Main mirror manufacturing accuracy	≥ λ/6 P – V at 630nm
Mirror material	Low-expansion borosilicate glass (LEBG)
Mirror coatings	Protected aluminium
Transmittance	≥ 77% at VIS; ≥ 77% at NIR;

FAPA

System for expanded control/testing IR FPA sensors

	<ul style="list-style-type: none"> ≥ 86% at SWIR; ≥ 92% at MWIR; ≥ 93% at LWIR
<i>TS target slider</i>	
Positions	At least five target positions
<i>Set of targets</i>	
Type of patterns	<ol style="list-style-type: none"> 1. IR horizontal edge target (edge length: 25mm, slant 5°) 2. IR vertical edge target (edge length: 25mm, slant 5°) 3. IR Slit target (slit width: 1.00mm) 4. IR pinhole (pinhole size: 1.00mm) 5. IR pinhole (pinhole size: 2.00mm)
<i>FS filter slider</i>	
Positions	At least two filter positions
<i>Set of spectral filters</i>	
Type of filters	<ol style="list-style-type: none"> 1. MWIR band pass filter (approx. band 3600 – 4800nm) 2. LWIR band pass filter (approx. band 8100 – 11500nm)
<i>Set of reference IR optical objectives</i>	
Type	<ol style="list-style-type: none"> 1. 50mm f/2 MWIR reference objective 2. 50mm f/1.2 LWIR reference objective
<i>YSS3D computerized x-y-z stage</i>	
Task	Ultra precision x-y-z stage that enables regulation of position of reference IR objective and position of image created by this objective
Modes	<ol style="list-style-type: none"> 1. Rough movement: 5 μm 2. Precision movement: 1 μm
Focusing range	≥ 14 mm
Focusing resolution	≥ 2.5 μm
<i>XPPI platform</i>	
Task	Manual vertical platform for rough vertical position
Movement range	At least ± 15mm
<i>HC height changer</i>	
Task	Mechanical block that increase height of optical axis of the CDT760 collimator to be equal to optical axis of the IR objective (needed due to mechanical constraints generated by YSS3D stage)
<i>PC set with analog, and LVDS framegrabber (one PC for FAPA test system)</i>	
Type	Standard PC tested for frame grabber compatibility CPU: Intel or AMD, RAM: ≥16 GB, SSD: ≥240 GB OS: Windows 10 or better
Framegrabbers	<ol style="list-style-type: none"> 1. Analog (PAL/NTSC) 8 – bit: BNC input 2. parallel Camera Link Base input, up to 200 megabytes per second, up to 28 bit LVDS per card, up to 85MHz speed, attention: frame grabbers can be changed if different interfaces are needed
<i>Software</i>	
ROB Control program	control of YSS3D computerized x-y-z stage
TAS-FI program	measurements as in Table 4

FAPA

System for expanded control/testing IR FPA sensors

8 FAPA-C system

FAPA-C (photo at Fig. 4) is an exceptional sub-system of FAPA system. It is the only subsystem that enables testing raw IR FPA sensors before integration with ROIC electronics. It enables spatial responsivity tests (mainly measurement of crosstalk) of such raw sensor.

FAPA-C system looks apparently as non important because basically cross talk of IR FPA sensors can be also measured using FAPA-I presented in previous section. However, there are two main differences:

1. FAPA-C enables direct measurement of cross-talk of raw IR FPA sensors when FAPA-I enables typically indirect (via measurement of MTF) measurement of cross-talk of a set: raw IR FPA sensor and ROIC electronics,
2. FAPA-C enables ultra accurate measurement of cross-talk of raw IR FPA sensors (including weak cross talk between far away pinholes) when FAPA-I enables only measurement of strong crosstalk between neighbor pixels. Practical experiments have shown that weak crosstalk between active pixel and hundreds of far away pixels can be as important as strong crosstalk between active pinhole and its neighbor pinholes. The prime example is situation when image of aircraft located on cold sky background becomes distorted due to influence of warm large ground targets and warm clouds.

In such a situation FAPA-C is a very valuable tool that help to optimize manufacturing of raw IR FPA sensors and to develop sensors having very small cross talk and near perfect MTF (both parameters are related).

It should be noted that FAPA-C is based on a special spot projection system capable to project image of spot below 8 μm . It is a level that competing systems cannot achieve.

Tab. 6. Performance parameters of FAPA-C station

Parameter	Value
<i>Sensor</i>	
Tested sensors	Sensors having at least low sensitivity to light at 1.3 μm (option: at 1.5 μm) – all SWIR sensors, great majority of MWIR sensor and some LWIR sensors
Accessories	Customer is responsible to deliver sensor in dewar and having active pixel bonded to preamplifier preferable dewar having floor window
Pixel size of tested sensor	Typically > 8 μm , Option < 8 μm
Required responsivity at 1.3 μm	> 0.01 A/W (contact Inframet is responsivity below this level)
Distance from input mechanical plane of dewar (wall with window) to sensor plane	< 10 (can be optionally increased)
Specifications window in dewar	must be approved by Inframet
<i>Dewar configuration</i>	
Light spot projector	At least 15×15 mm
Max power of light spot	At least 2 mW
Light spot diameter	< 6 μm at 70% of light power
Dynamic of regulation of light power	At least 100 times
Optics	F1.5 diffraction limited
Control	From PC via USB
<i>Scanning system</i>	
XY scanning area	At least 10×10 mm
Scanning resolution	Rough movement – 2.5 μm Precision movement: 0.5 μm
Focusing range	10 mm
Focusing resolution	0.5 μm
Control	From PC via USB

Tab. 7. Performance of key modules – FAPA-C

Parameter	Value
<i>Laptop or PC(in case of delivery full FAPA test system)</i>	
Type	Standard laptop tested for test system compatibility CPU: Intel or AMD, RAM: ≥ 8 GB, SSD: ≥ 240 GB OS: Windows 10 or better

FAPA

System for expanded control/testing IR FPA sensors

Software	
Control / measurement	Spot control program

Due to big design and application differences FAPA-C is offered commercially in two forms:

1. subsystem of bigger FAPA system,
2. independent test system coded as SPOT.

Technically both forms are the same.

Technical details of FAPA-C (SPOT) are presented at https://www.inframet.com/Data_sheets/Spot.pdf

9 FAPA-S system

The aim of FAPA-S system (photo at Fig. 5) is to enable spectral tests of IR FPA sensors/camera cores. In detail, FAPA-S is used to measure relative spectral sensitivity. Measurement of this parameter is often considered as non important. The reason is that typical scientists/engineers believe that relative spectral sensitivity of typical IR FPA sensors is a parameter that varies depending of type and is approximately known. It is expected following spectral bands 1) non cooled LWIR sensors are approximately sensitive in 8-14 μ m band, 2) cooled MWIR FPAs are to be sensitive in 3-5 μ m band, 3) cooled LWIR FPAs are to be sensitive in 8-12 μ m band.

However, the rules above are often broken and measurement of relative spectral sensitivity of IR FPA sensor can deliver useful know how about potential use of the sensor in thermal imaging system.

Longwave limit of non cooled LWIR sensors is often lowered to 12 μ m band in order to reduce influence of atmospheric attenuation. The shortwave limit of non cooled LWIR sensors can also vary in range of 7.5 μ m to 8.5 μ m.

Further on, there are on market non cooled broadband IR FPA sensor sensitive from about 2 μ m to about 14 μ m.

Relative spectral sensitivity of cooled MWIR FPAs often differs from classical 3 μ m to 5 μ m. Knowledge about real relative spectral sensitivity of MWIR FPA is of critical importance to model atmosphere influence on performance of cooled MWIR imagers and sensitivity of such imagers to MWIR lasers. The same can be said on relative spectral sensitivity of cooled LWIR FPAs.

There are also two additional parameters (peak spectral responsivity R, peak spectral normalized detectivity D*) that can be measured using FAPA-S.

Table 8. Test capabilities of of FAPA-S

Direct measurement
1. Relative spectral sensitivity
2. Peak spectral responsivity R,
3. Peak spectral normalized detectivity D*.

FAPA-S station is a system that irradiate tested IR FPA sensor, measure reactions of the sensor to this radiation and calculates spectral parameters of this sensor. In detail, the FAPA-S system performs three functions:

1. Irradiation of a part of tested IR FPA sensor using radiation of variable wavelength and of known intensity,
2. Electronic control of tested IR FPA sensor by delivery of proper bias voltages and clocking (this function is done by typical CONIR block).
3. Remote control of monochromator, image acquisition, computing of video images generated by tested sensor, calculation of spectral parameters.

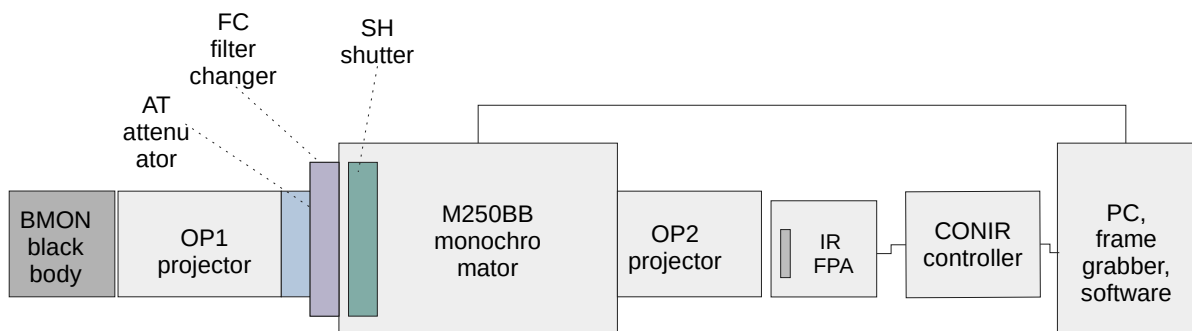

Fig. 11. Block diagram of FAPA-S station

Total list of modules is as below:

1. SPECTR irradiator
 1. BMON blackbody

FAPA

System for expanded control/testing IR FPA sensors

2. OP1 optical projector - to project image of emitter of BMON blackbody to input slit of the monochromator and to optimize incoming beam to monochromator optics,
3. AT attenuator
4. FC filter changer - to enable easy exchange of edge filters needed to eliminate problems with harmonics of main wavelength to be transmitted,
5. Set of 3 edge filters ,
6. SH shutter - to enable simulation of low temperature background,
7. M250BB monochromator - to work as variable wavelength narrow band filter of regulated wavelength,
8. OP2 optical projector - to project image of monochromator slit to plane of IR FPA sensor of tested camera core,
9. PC
10. set of frame grabbers
11. software)

Tab. 9. Specifications of key modules of FAPA-S

Parameter	Value
<i>BMON blackbody</i>	
Spectral band	at least 3 – 14 μ m
Aperture	at least 5 mm
Maximum temperature	$\geq 800^{\circ}\text{C}$
Emissivity	at least 0.85
Temperature calibration	non calibrated
<i>OP1 optical projector</i>	
Spectral band	at least 3 – 14 μ m
Transmission	at least 0.8
magnification	at least 1
<i>AT attenuator</i>	
attenuation range	at least 10 times
<i>FC filter changer</i>	
Positions	At least three filter positions
<i>Set of three edge filters</i>	
Quantity	Three
attenuation of harmonic frequencies form output monochromator signal	at least 100 times
<i>SH shutter</i>	
movement speed	below 1 sec
emissivity	at least 0.9
<i>M250BB monochromator</i>	
Task	To work as variable wavelength narrow band filter of regulated wavelength
Spectral range	At least 3 – 14 μ m
Spectral band	depends on input/output slits but can be achieved 30nm at MWIR 60 nm at LWIR
<i>OP2 optical projector</i>	
Spectral band	at least 3 – 14 μ m
Transmission	at least 0.7
PC	Standard PC tested for frame grabber compatibility CPU: Intel or AMD, RAM: ≥ 16 GB, SSD: ≥ 240 GB OS: Windows 10 or better
Set of frame grabbers	1. Analog (PAL/NTSC) 8 – bit: BNC input

FAPA

System for expanded control/testing IR FPA sensors

	2. parallel Camera Link Base input, up to 200 megabytes per second, up to 28 bit LVDS per card, up to 85MHz speed, attention: frame grabbers can be changed if different interfaces are needed
<i>Software</i>	
WAVE Control program	control of M250 monochromator
TAS-FS	measurement of relative spectral sensitivity

10 Versions

FAPA is a modular test system can be delivered in different versions of different design, different test capabilities and at different price level. The version can be precisely determined using the five digit code as shown in the table below.

Tab. 10. Versions of FAPA test system

Subsystem	YES	NO
CONIR	1	0
FAPA-N	1	0
FAPA-I	1	0
FAPA-C	1	0
FAPA-S	1	0

Code FAPA 11111 means FAPA system that includes CONIR controller and all four FAPA subsystems: N, I, C and S. Such test system can be used for testing both complete IR FPA sensor, raw IR FPA sensors (crosstalk, MTF) and camera cores.

Code FAPA 01111 means FAPA system of potentially can measure the same number of parameters of complete IR FPA sensor, raw IR FPA sensors (crosstalk, MTF) and camera cores but CONIR is not included and customer must have its own controller of IR FPA sensors.

Code FAPA 11000 means FAPA system in most typical FAPA-N configuration (including CONIR) capable to control IR FPA sensors and do noise/responsivity tests.

11 Options

Inframet can optionally deliver

1. AT optical table to be used as platform for FAPA system.
2. Additional DT system for testing complete thermal imagers (coded as FAPA-DT)
3. EL customized test station to enable powering and basic electrical tests of cooled thermal camera cores using Stirling coolers. EL is to enable following functions:
 1. Power supply and measurement of power consumption of cooler of tested cooled thermal camera core (max voltage 60V, max current 20A)
 2. Measurement of cool down time of tested IR FPA sensor (DT-670 temperature sensor or 2N2222 transistor).

*specifications are subject to change without prior notice

Data sheet version 10.2

CONTACT:

Tel: +48 604061817

Fax: +48 22 3987244

Email : info@inframet.com